

For finishing processes resin automatic compounding device

TK KITCHEN

Automatically formulate the resin stock solution directly to the specified concentration!



【CHARACTER】

LABOR SAVING

No need for a full-time worker for liquid preparation work!

TANKLESS

The undiluted solution is mixed directly, and no liquid preparation tank is required!

SIGNIFICANT REDUCTION IN LIQUID CHANGE TIME

It is possible to change the liquid smoothly in a short time!

REDUCTION OF LIQUID PREPARATION LOSS

By creating only the required amount, loss due to overproduction is reduced!

Reduction of resin liquid by reducing liquid preparation mistakes

CENTRALIZED MANAGEMENT OF WORK

Troublesome liquid preparation work is completed just by operating the panel!

STABILIZATION OF QUALITY

Stable resin liquid formulation and supply reduces variations in texture !



1-2 NESHINDEN, NISHIBIWAJIMA-CHO,
KIYOSU ACHI, JAPAN

TEL +81- 52-503-1499

FAX +81- 52-503-1499

E-mail : setubi@tokai-senko.co.jp

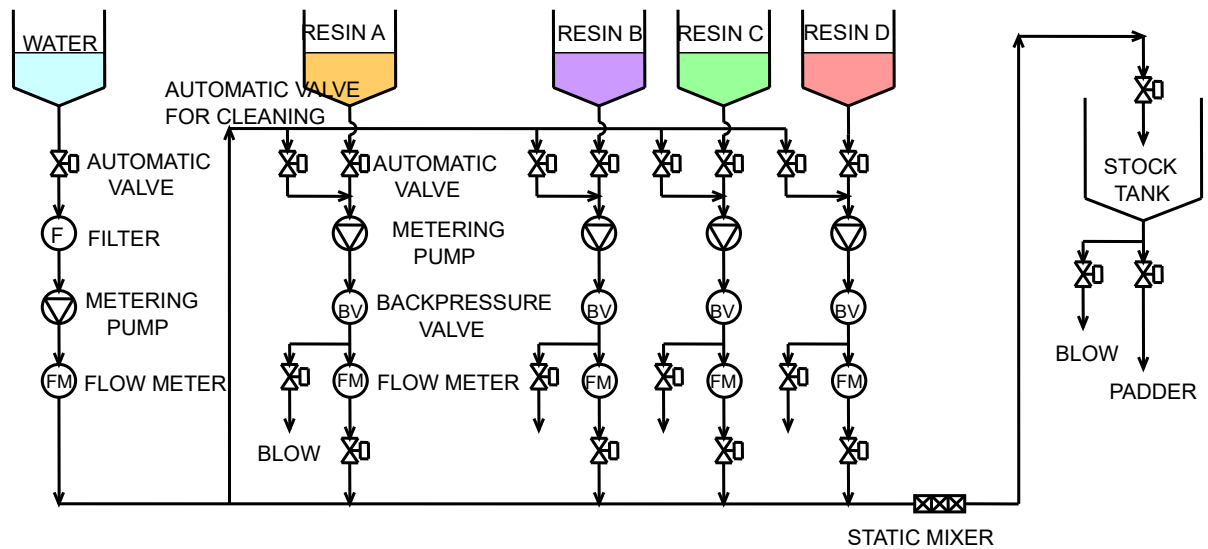

TK KITCHEN compounding flow

[CONTINUOUS SUPPLY]

1. WATER SUPPLY
A certain amount of water (40L / min) is supplied from the water supply unit.
2. WEIGHING RESIN STOCK SOLUTION
THE resin stock solution stocked in the service tank is supplied by a metering pump. The amount of liquid supplied at this time is based on the processing prescription registered in advance, with respect to the amount of water supplied from the water supply unit. The required amount of resin liquid is automatically calculated, measured, and supplied.
3. MIX, DISSOLVE, stock
The weighed and supplied water and resin liquid are mixed and dissolved by a static mixer in the piping. It will be stocked in the service tank.
4. Resin liquid supply the resin liquid stocked in the stock tank is supplied according to the amount of liquid in the processing tank. In addition, if the stock amount in the stock tank decreases, it will be mixed and stocked again according to the procedure from ①.

[Batch type supply]

If you do not use the TK kitchen for continuous supply, you can prepare and stock it in another stock tank in advance. It will be possible to use the TK kitchen efficiently.